



# Revere Granite Double Bowl Sink RVGLB3322 Series

## Specifications

### FEATURES:

- Top mount
- Revere granite material
- 9-1/2" (241mm) deep
- 3/8" (10mm) rim height
- 4" (102mm) bridge height
- Faucet holes are pre-scored for flexible installation, installer can punch up to 5 holes
- Color Options with natural accents:  
Black (BK), Bisque (BQ), Brown (BR), or White (WH)
- 3-1/2" (89mm) drain opening
- Minimum cabinet size: 36" (914mm)
- Sink complies with ANSI Z124.6 and CSA B45-02



These sinks are listed by the International Association of Plumbing and Mechanical Officials as meeting the requirements of the Uniform Plumbing Code and the National Plumbing Code of Canada.

### OPTIONAL ACCESSORIES:

- Drains: S1
- Bottom Grids: RVWOBG1417LSS (Left Bowl), RVWOBG1417RSS (Right Bowl)
- Cutting Board: RVCB1417HW

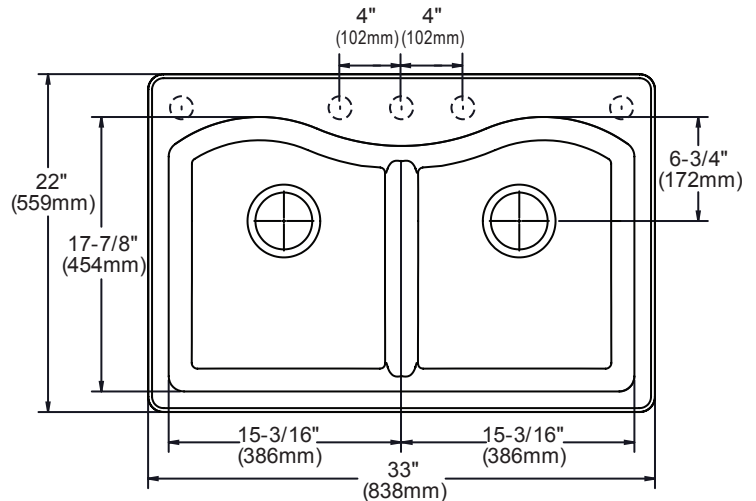

Cross Profile of Installation

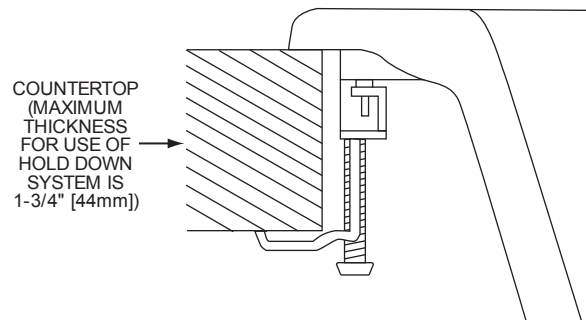

In keeping with our policy of continuing product improvement, Revere reserves the right to change product specifications without notice.

This specification describes a Revere product with design, quality and functional benefits to the user. When making a comparison of other producers' offerings, be certain these features are not overlooked.

Revere • 2222 Camden Ct. • Oak Brook, IL 60523 • [reveresink.com](http://reveresink.com) • Tel: (800) 225-8585 • Fax: (630) 645-4447