



Revere Granite Double Bowl Sink RVG250R Series

Specifications

FEATURES:

- Top mount
- Revere granite material
- 9-1/2" (241mm) deep
- 3/8" (10mm) rim height
- Faucet holes are pre-scored for flexible installation. Installer can punch up to 4 Faucet holes
- Color Options with natural accents: Black (BK), Bisque (BQ), Brown (BR), or White (WH)
- 3-1/2" (89mm) drain opening
- Minimum cabinet size: 36" (914mm)
- Sink complies with ANSI Z124.6 and CSA B45-02



These sinks are listed by the International Association of Plumbing and Mechanical Officials as meeting the requirements of the Uniform Plumbing Code and the National Plumbing Code of Canada.

OPTIONAL ACCESSORIES:

- Drains: S1

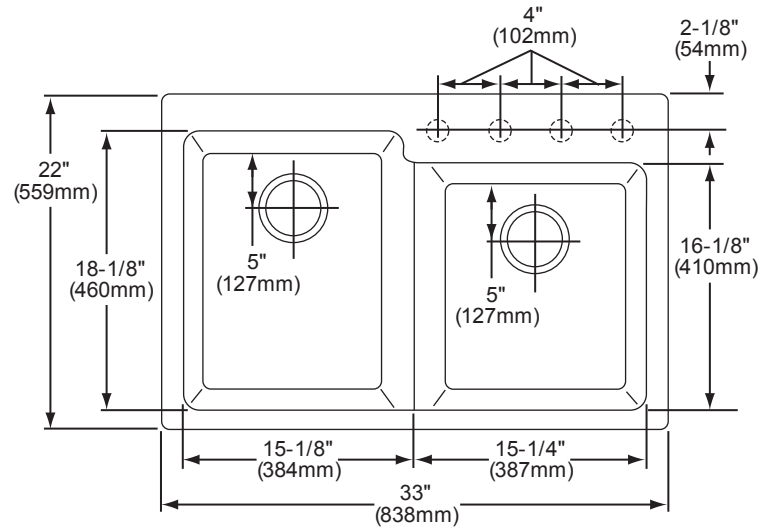

Cross Profile of Installation

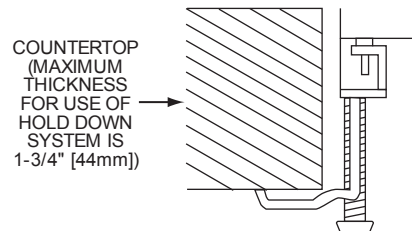

In keeping with our policy of continuing product improvement, Revere reserves the right to change product specifications without notice.

This specification describes a Revere product with design, quality and functional benefits to the user. When making a comparison of other producers' offerings, be certain these features are not overlooked.

Revere • 2222 Camden Ct. • Oak Brook, IL 60523 • reversesink.com • Tel: (800) 225-8585 • Fax: (630) 645-4447