



Double Bowl Sink NLPF33224

Specifications

Features

- Top Mount
- 20 gauge stainless steel
- Durable Satin Finish
- 8-1/4" (210mm) Depth
- Overall Size: 33" x 22" (838mm x 559mm)
- 3-1/2" (89mm) center drain opening
- Faucet holes: (4) 1-1/2" (38mm) diameter
- Cutout Dimensions: 32-3/8" x 21-3/8" (822mm x 543mm) with 1-1/2" (38mm) radius corners.
- Mounting hardware for countertops up to 3/4" (19mm) thick included.
- Sound insulation - spray undercoating on bottom
- Minimum cabinet size: 36" (914mm)
- Limited lifetime warranty

RECOMMENDED ACCESSORIES

Bottom Grid: NBG1416CR, LKWBG1416SS

Cutting Board: CB1516

Drain: D1125, LK35, LK99

Faucet Hole Cover: LK125R

Rinsing Basket: NRB1416CR, LKW RB1316SS (LKWUCSS)

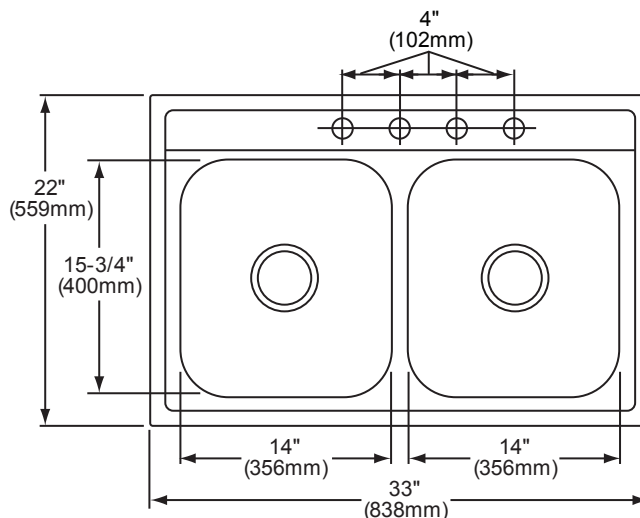

In keeping with our policy of continuing product improvement, Revere reserves the right to change product specifications without notice. Please visit reversesink.com for most current version of Revere product specification sheets.

This specification describes a Revere product with design, quality, and functional benefits to the user. When making a comparison of others producers offerings, be certain these features are not overlooked.